



**nLight AIR**  
Emergency Solutions  
EM Options

# New UL 924 Standards - Is Your Project Ready?

As of May 6th, 2022, a UL 924 change is effective that obsoletes many industry-standard emergency solutions. This update requires emergency lighting control devices to be provided with an input signal indicating the presence of normal power. The nLight AIR EM emergency solution (EM) meets this requirement wirelessly.

## Less Wiring, Less to Install

EM is designed for projects with external emergency power sources, such as generators or inverters, and delivers a lower cost of install than traditional solutions by eliminating dedicated wiring used to sense normal power. Instead of requiring additional wiring, nLight AIR devices connected to normal power wirelessly communicate with EM devices to advise when normal power is available.

## Benefits

### Significant Savings:

By avoiding additional wiring that is used to sense the availability of normal power, EM reduces emergency lighting installation costs by as much as 40%.

### Robust Emergency Application Offering:

Field installable and fixture embedded EM options are available for commercial indoor, hospital, warehouse, industrial, parking garage, outdoor spaces, and more.

### UL 924 Compliant:

EM devices comply with UL 924 updates that are effective as of May 6th, 2022.

### Built-In Normal Power Sense:

A variety of nLight AIR devices have a built-in feature to sense the availability of normal power, providing emergency zone sensing for EM devices often without the need for additional hardware.

### Quick Test Feature:

The CLAIRITY™+ mobile app includes a quick test feature that simulates normal power being lost, reducing the need to access critical areas to cycle breakers.



# Simple and Fast

The example one-line below shows the simplicity of the overall system, and the timeline describes the quick response of EM devices to loss of power.

## A Versatile, Uncomplicated Solution

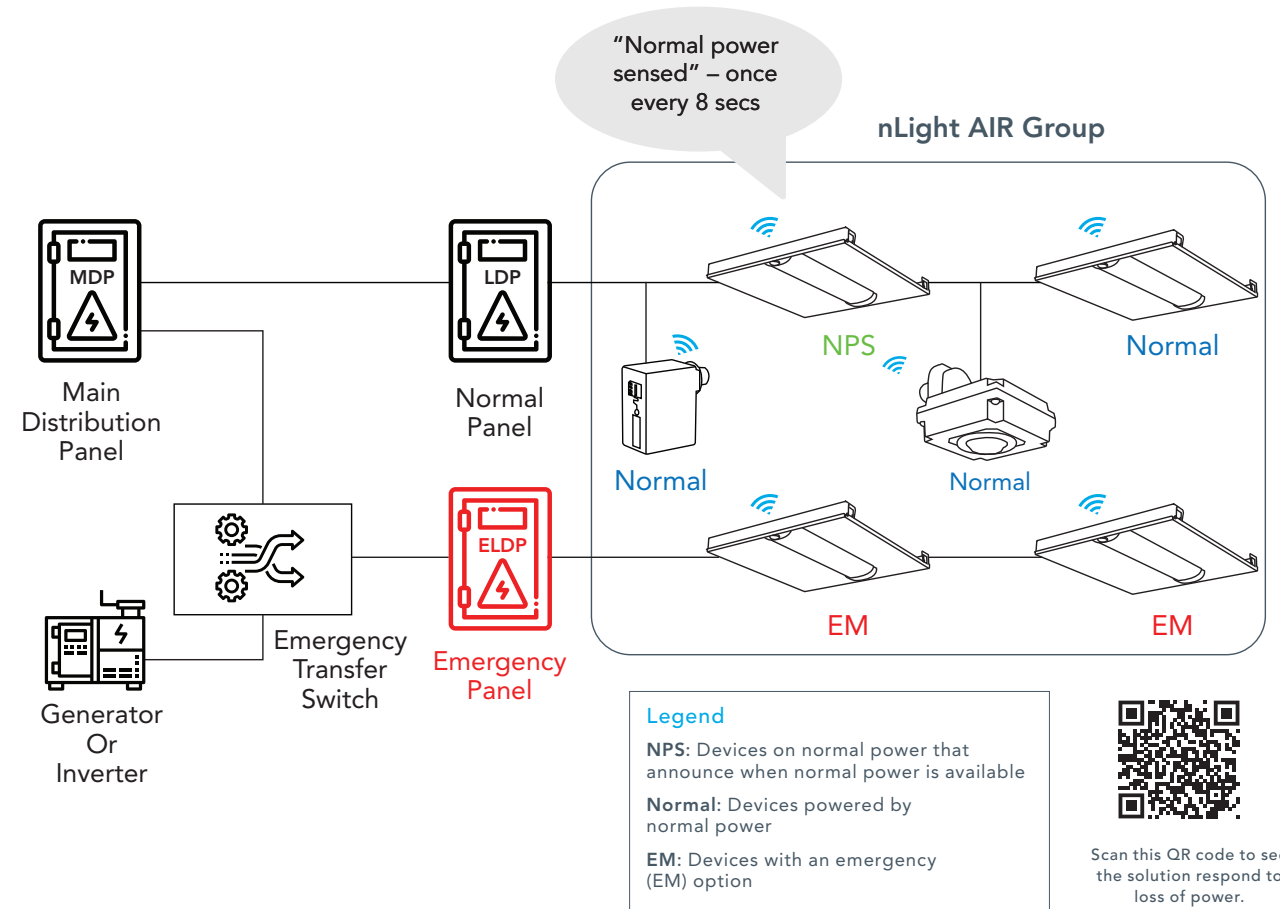

## Predictable Emergency Response

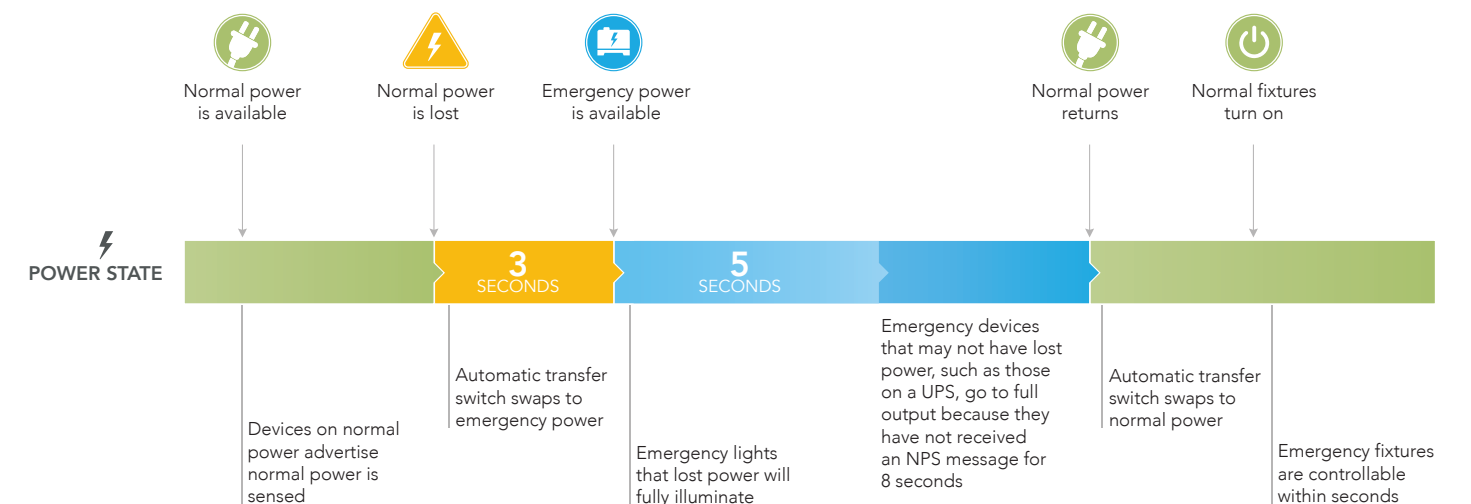

# External Emergency Power Sources

nLight AIR EM devices require less wiring than other emergency solutions, and when embedded inside a luminaire, installation is further reduced. The examples below help visualize how EM simplifies installation, benefiting projects that use external emergency power sources.

## Solution 1 (Compliant): External Controls and Shunts

Features	Included
UL 924 compliant	✓
Built-in emergency option	✗
Avoids 0-10V wiring	✗
Avoids normal power sense wires	✗

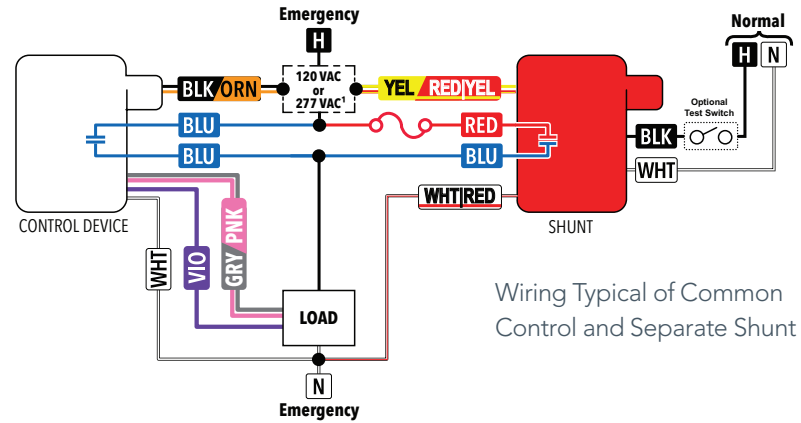

Features	Included
UL 924 compliant	✓
Built-in emergency option	✓
Avoids 0-10V wiring	✗
Avoids normal power sense wires	✗

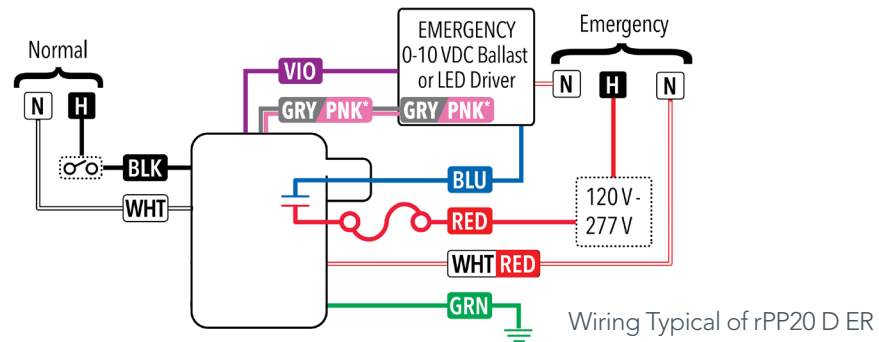

## Solution 2 (Good): nLight AIR External Controls With EM

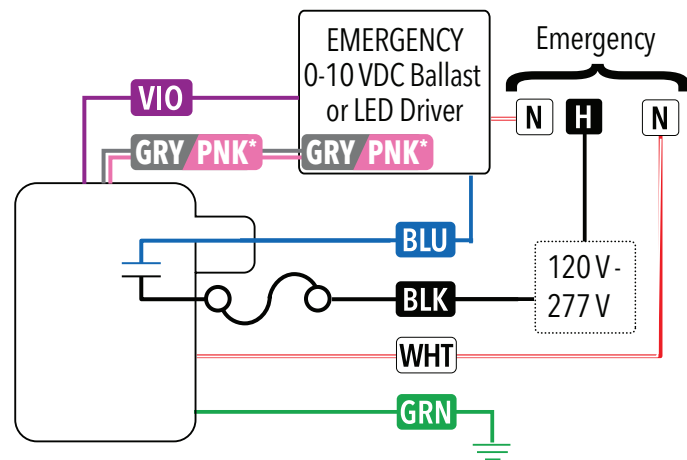

Features	Included
UL 924 compliant	✓
Built-in emergency option	✓
Avoids 0-10V wiring	✗
Avoids normal power sense wires	✓

Wiring Typical of rPP20 D EM, rLSXR EM, rSDGR EM

## Solution 3 (Good): Wireless Control Embedded With Shunt

Features	Included
UL 924 compliant	✓
Built-in emergency option	✓
Avoids 0-10V wiring	✓
Avoids normal power sense wires	✗

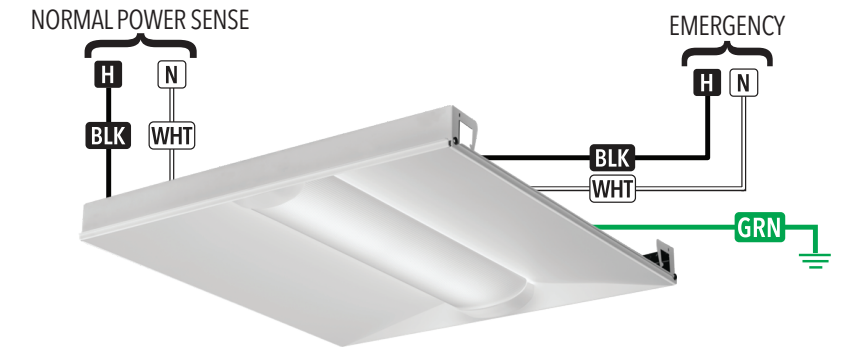

## Solution 4 (Best): nLight AIR Embedded With EM

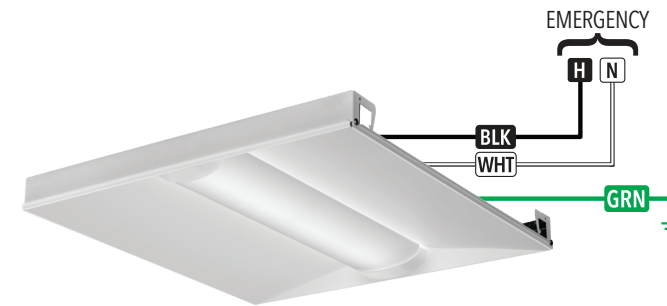

Features	Included
UL 924 compliant	✓
Built-in emergency option	✓
Avoids 0-10V wiring	✓
Avoids normal power sense wires	✓

Scan the below to see more information on nLight AIR enabled luminaires.



# Integrated Battery Packs

Battery packs are an alternative to external emergency power sources. Though nLight AIR EM devices are intended for external power source solutions, battery pack installations also benefit from nLight AIR.

## Solution 1 (Good): Non-EM External Control and Battery Pack

Features	Included
UL 924 compliant	✓
Built-in emergency option	✓
Avoids 0-10V wiring	✗
Avoids normal power sense wires	✗

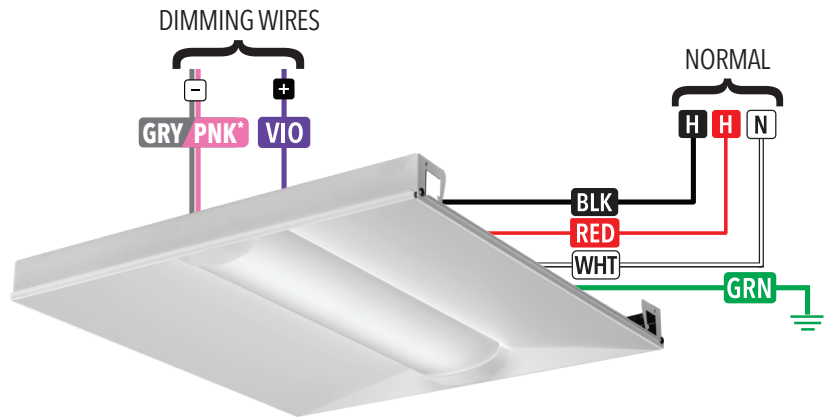

## Solution 2 (Best): Non-EM nLight AIR Embedded and Battery Pack

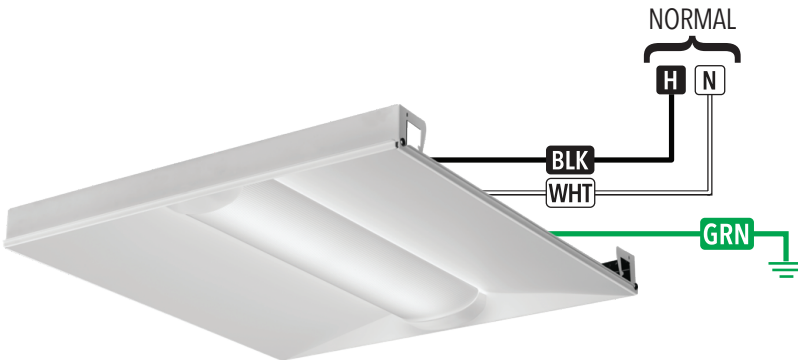

Features	Included
UL 924 compliant	✓
Built-in emergency option	✓
Avoids 0-10V wiring	✓
Avoids normal power sense wires	✓

For more information on the nLight system, for design support, or for a quick sample bill of materials, contact us at: [www.acuitybrands.com/support/how-to-buy](http://www.acuitybrands.com/support/how-to-buy)

Lighting Control Representative:

Name: \_\_\_\_\_

Phone: \_\_\_\_\_ Email Address: \_\_\_\_\_